

# Model DG150WW

## Manually Loaded Automatic Cleaning System

### Applications

- Accommodates substrates mounted on film frames, tape rings or un-mounted
- Film frames for round substrates up to 6" (150mm)
- Square substrates up to 6" x 6" (150mm x 150mm)
- Typical system applications:
  - Wafer cleaning after dicing
  - Photomask cleaning
  - Thin Film substrate cleaning
  - Wafer flux cleaning (flip-chip)

### Product Description

The Denbeq DG150WW Automatic cleaning system is a manual load, automatic processing station used to clean various substrates of residual debris after processing. The system can be configured with different processes chucks to accommodate various frame sizes for substrates up to 150mm in diameter.

The cleaning process utilizes a processes chuck to securely hold the work piece in place while spinning during the wash and dry cycles. The wash cycle uses a reciprocating sweep arm to move a high pressure nozzle that sprays cleaning liquid onto the spinning work piece. When the wash cycle completes, the same reciprocating sweep arm uses an N2 blow nozzle to facilitate drying. The system is also equipped with an over head IR heat lamp to enhance the drying cycle.

Ease of operation, programming, maintenance, and repair where all-important criteria's during the designing of the Denbeq DG150WW. All electronics and pneumatics are located where they are visible and easy to reach. Operation of the machine is controlled by a PLC controller system that integrates LCD display and key buttons into one unit for easy programming of processes parameters. Interlocks alarms, sensor malfunctions, and operational system errors are also descriptively displayed on the controllers LCD display.



### Features

- Microprocessor based processes controller with LCD screen
- Easy to navigate on screen menus
- Digitally programmed wash and dry time parameters
- Adjustable spin speed control
- Wash spray pressure up to 2500 psi
- Cylinder actuated sweep arm with adjustable speed and travel
- N2 dry with IR heat lamp eliminates all residual water
- Large IR heat lamp shield stays cool to the touch
- Splash guard prevents contamination
- Large opening for easy access to load and unload substrate
- Interchangeable spin chucks - standard or custom designs
- Chuck vacuum, N2 pressure, exhaust and cover safety interlocks
- External house drain and exhaust
- Small footprint - custom enclosures available

**DENBEQ**  
CORPORATION

**Simple is Reliable**

1833 West Main #126 | Mesa AZ 85201 | Tel 602 308-4848 | Fax 877 554-1477

[www.Denbeq.com](http://www.Denbeq.com)

## PROCESS CONTROL SYSTEM

### Reciprocating Sweep Arm

- Wash spray and N2 dry are integrated into single arm
- Interchangeable nozzles for different spray volume
- Cylinder actuated sweeping movement
- Adjustable sweep speed, travel start and stop locations

### Washing System

- Adjustable spray pressure up to 2500 psi
- Pressure release dump valve prevents nozzle drips

### Drying System

- Adjustable N2 dry pressure
- IR heat lamp 250 Watt

### Spin motor

- Direct drive spindle with DC motor
- Spin speed 100 to 3,600 rpm

### Inter Changeable Chucks (Customer Specified)

- Film frame chucks with alignment pins. Vacuum hold down of substrate and centrifugal pendulum clamps for frame
- Un-mounted substrate chucks with vacuum hold down
- O-ring chucks for photo masks

## SOFTWARE

### PLC Processes Controller

- Time programmable wash and dry steps (2 Steps)
- Timing Range 1 to 999 seconds (1 second increments)
- Plain English on screen operation prompts and errors
- Easy to navigate on screen menus for programming processes parameters

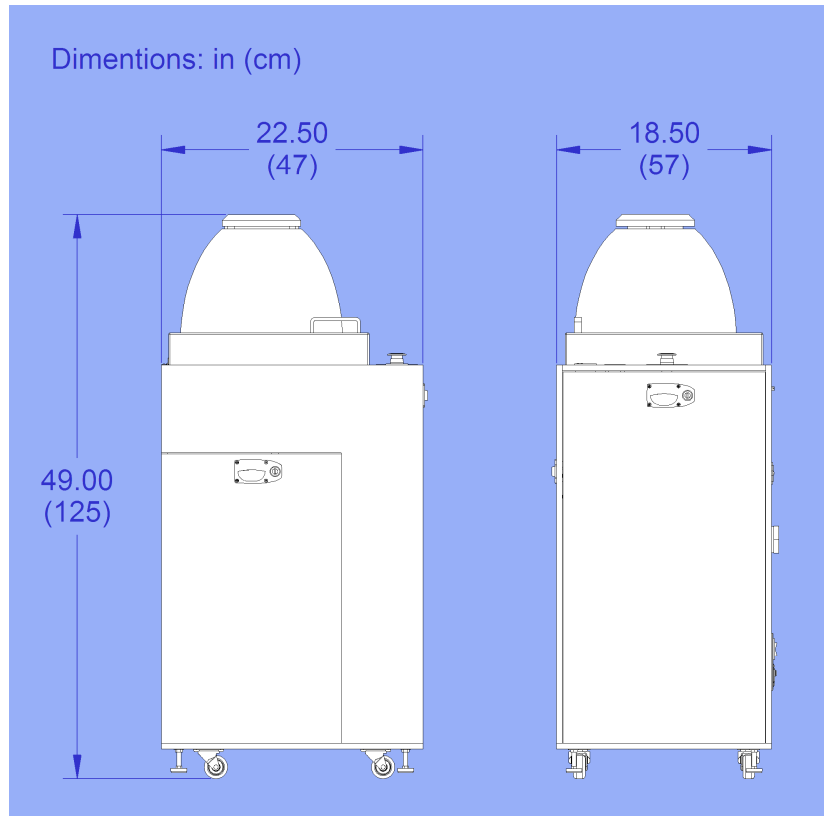

## FACILITIES AND INSTALLATION SPECIFICATIONS

Facilities	Requirement*	Hookup
Power Requirements	115V AC - 60Hz - 6 Amp Max	3 prong D-type Receptacle
Nitrogen	80 psi (5,5 bar) minimum	1/4" OD tube quick connect
Water	10 psi (0,7 bar) minimum	1/8" Female NPT
Drain		3/4" Female NPT
Exhaust (If equipped)	100 cfm max, 0.5" H <sub>2</sub> O min	4" ID tube connection
Vacuum	Internal venture generator	
Dimensions (L x W x H)	22.5"x18.5"x49" (47x57x125cm)	
Weight	132 lbs (60kg)	
Operating Temperature	32° - 104° F (0° - 40° C)	

\*Requirements may vary depending on process

**DENBEQ**  
CORPORATION



For Sales Call:  
**Giorgio Technology**  
**Sales/Service**  
Office: (480) 917-3640  
[www.gtsaz.com](http://www.gtsaz.com)

**Simple is Reliable**